



# NEWPORT BOOKCASE HEADBOARD ATLANTIC FURNITURE

## ASSEMBLY INSTRUCTIONS

( TWIN )

Before assembling your Newport bookcase headboard, please read through these instructions carefully, familiarize yourself with the different parts.

Please note that you will require a Phillips Head Screwdriver, Hammer and an Allen wrench.

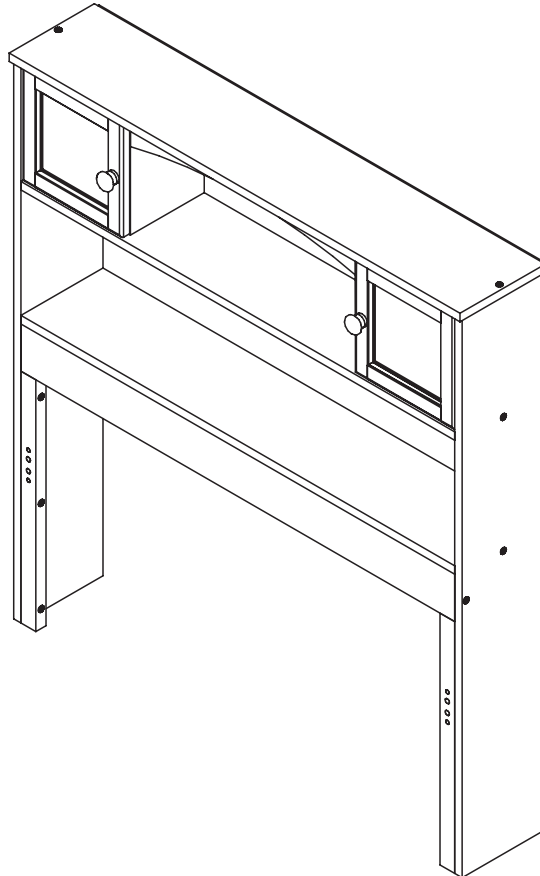
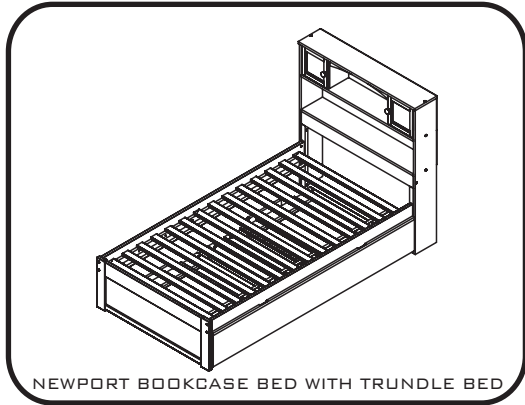
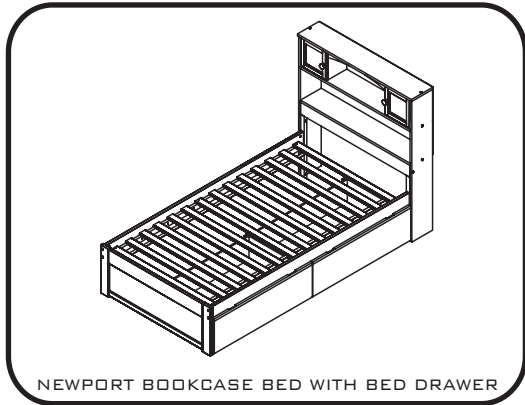
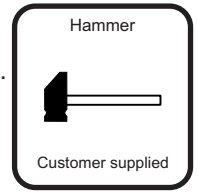

### HEADBOARD HARDWARE

NOTE : WE INCLUDE SPARE HARDWARE IN CASE THE ALLEN WRENCH, JCB, METAL PIN, BARREL NUT, NAIL OR WOOD SCREW ARE DAMAGED DURING ASSEMBLY.

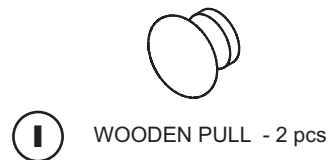
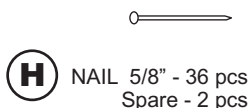
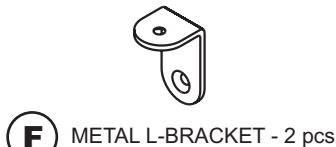
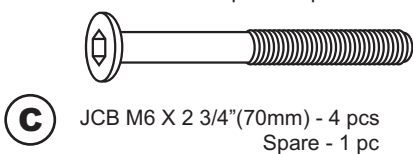
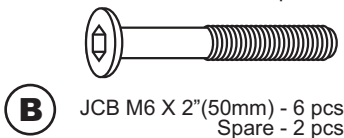
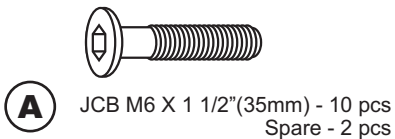

# HEADBOARD PARTS LIST

01	HARDWARE	1 BOX
02	TOP PANEL	1 PC
03	LEFT SIDE PANEL	1 PC
04	RIGHT SIDE PANEL	1 PC
05	TOP SHELF	1 PC
06	LEFT DIVIDER	1 PC
07	RIGHT DIVIDER	1 PC
08	LEFT DOOR	1 PC
09	RIGHT DOOR	1 PC
10	TOP RAIL	1 PC
11	BOTTOM SHELF	1 PC
12	PILLOW STOP	1 PC
13	LEFT POST	1 PC
14	RIGHT POST	1 PC
15	BACK PANEL	1 PC

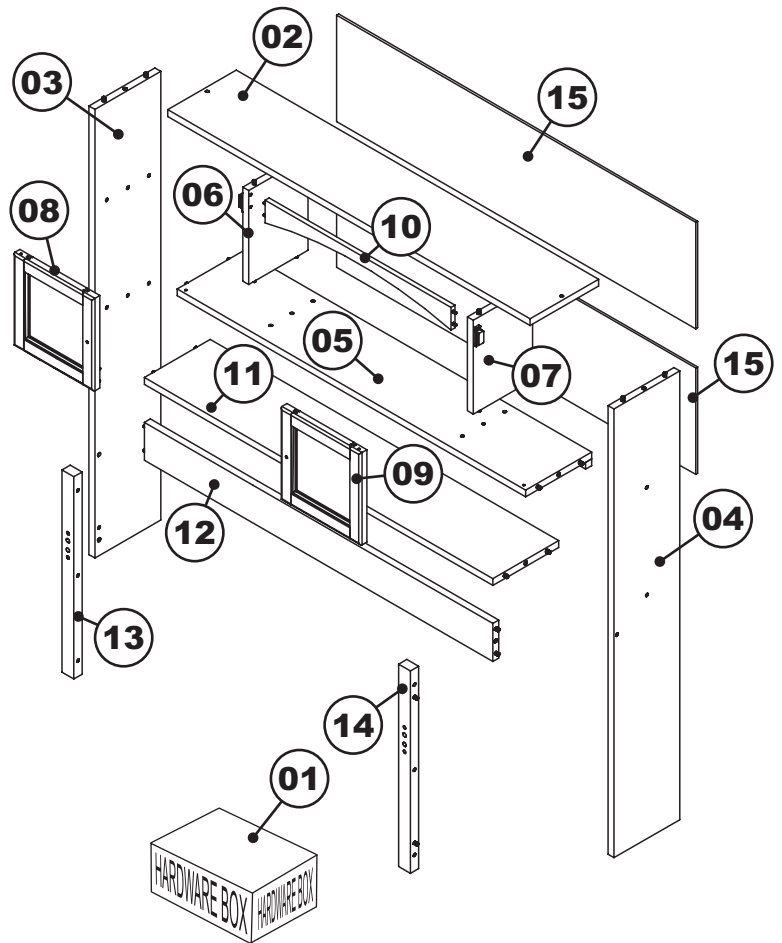

## STEP 1

Attach top rail (10) to the left, right divider (06)(07) assembling to the top shelf (05) as shown below. Using JCB (A) tighten with allen wrench (K).

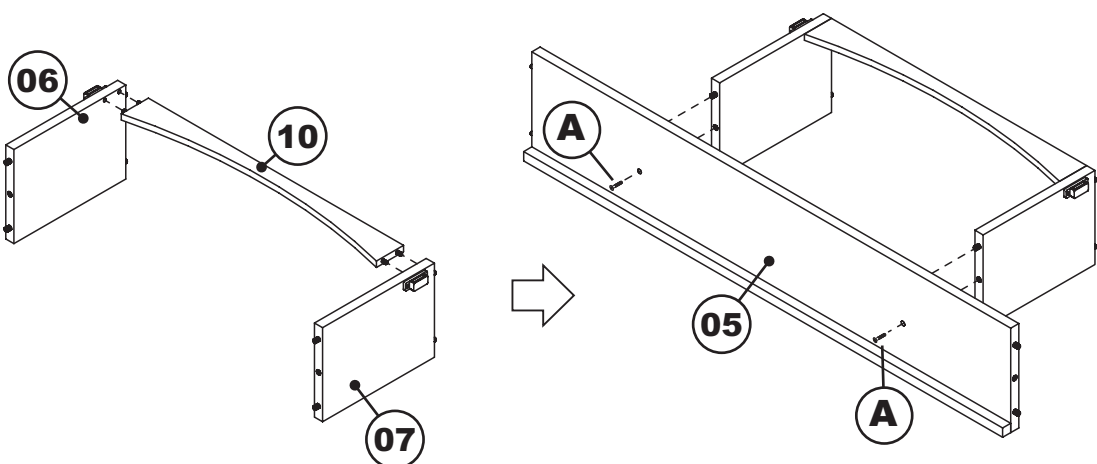
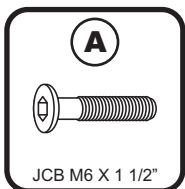

**STEP 2**

Attach left, right post (13)(14) to the side panels (03)(04) as shown below. Using JCB (B) tighten with allen wrench (K).

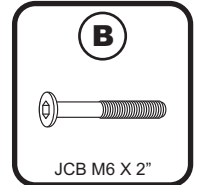
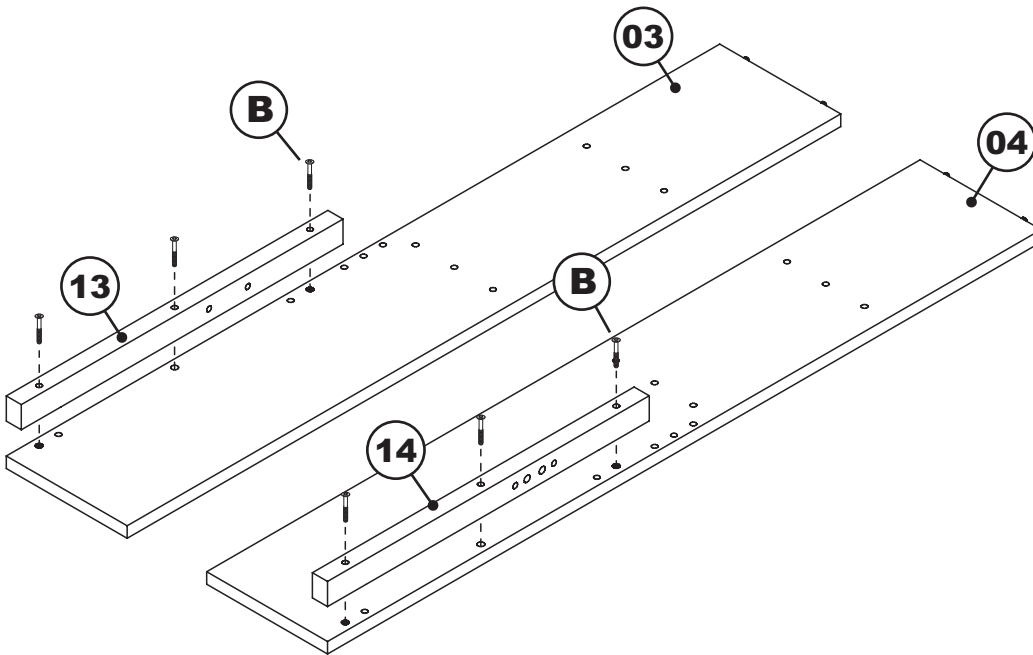
**STEP 3**

Attach the top shelf assemblies, bottom shelf (11) and pillow stop (12) to the side panels as shown below. Using JCB (A) tighten with allen wrench (K).

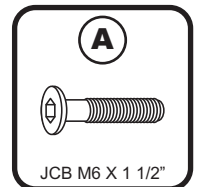
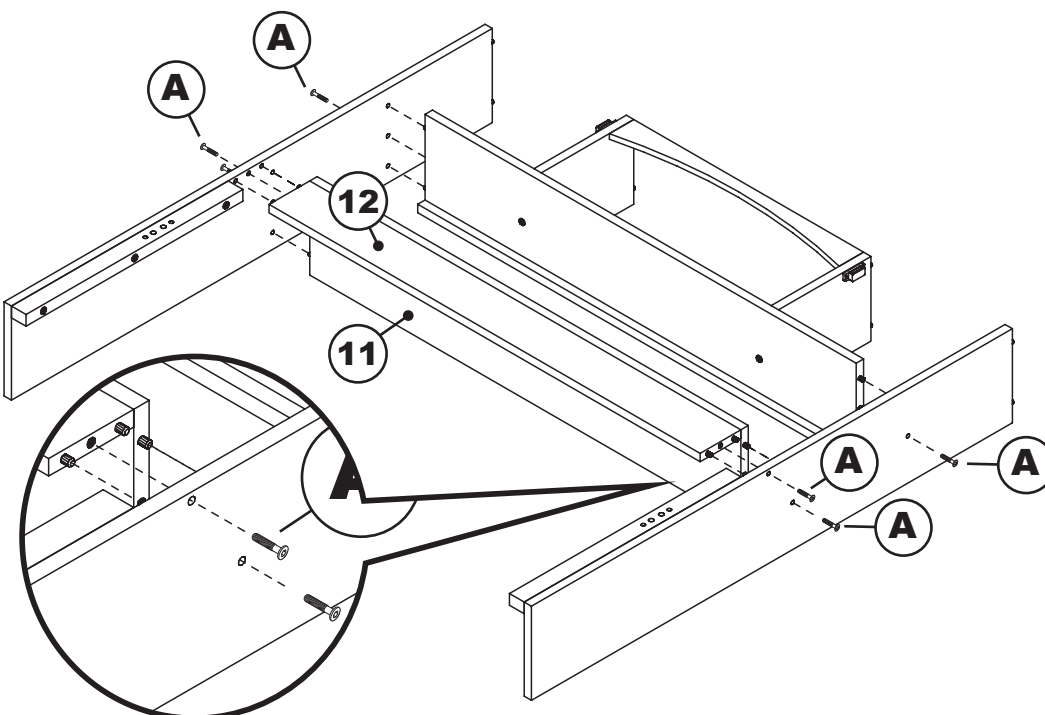

**STEP 4**

Install metal pin (E) to the locator hole will receive (E). Install wooden pull (I) as shown below. Using wooden pull screw (J) tighten with phillips head screwdriver. ( Customer supplied )

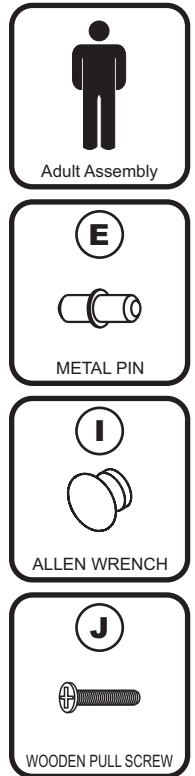
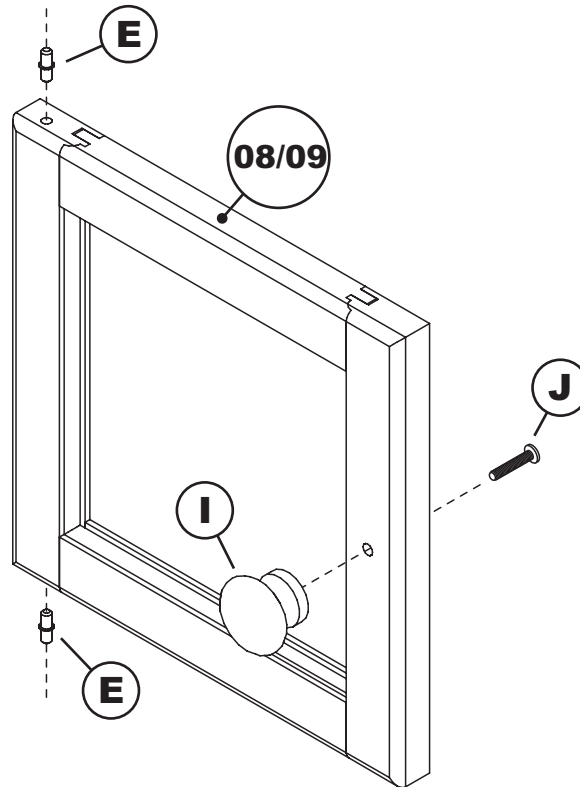
**STEP 5**

Attach left, right door (08)(09) and top panel (02) to the side panel assemblies as shown below. Using JCB (A) tighten with allen wrench (K). Be sure the magnet catch counterpiece of the door contact with magnet catch housing.

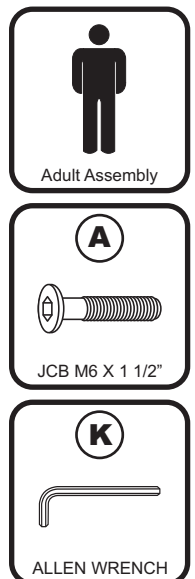
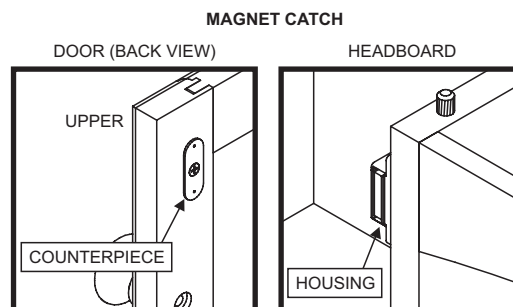
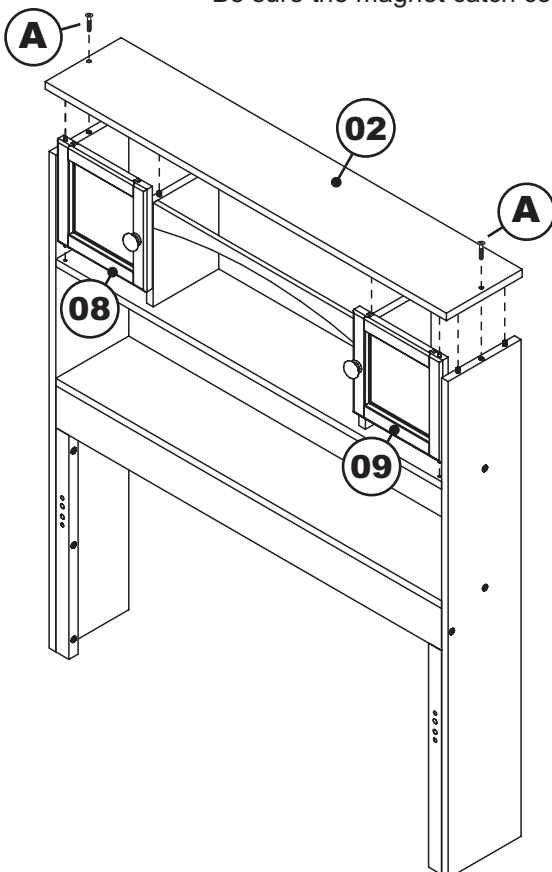

**STEP 6**

Attach back panel (15) as shown below. Using nail (H) tighten with hammering. Install metal L-bracket (F) using wood screw (G) tighten with phillips head screwdriver. (Customer Supplied)

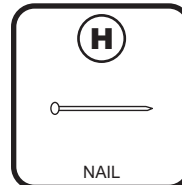
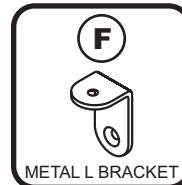
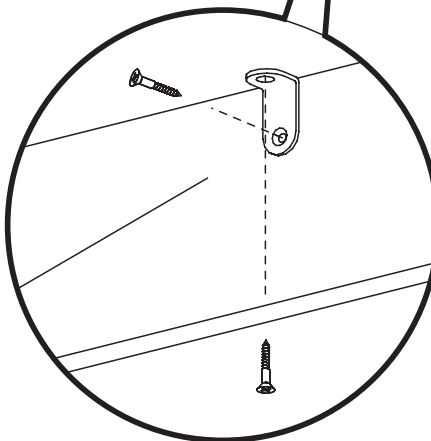
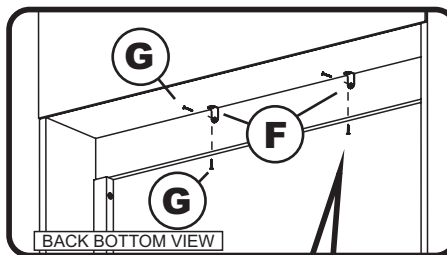
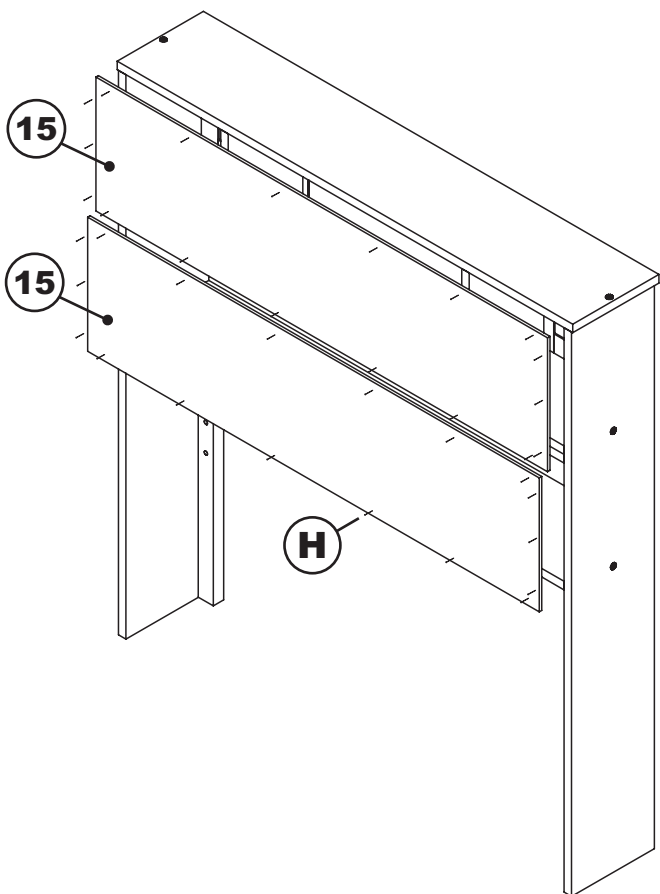

**STEP 7**

Attach headboard assemblies to the bed frame assemblies as shown below. Using JCB(C) and barrel nut (D) tighten with allen wrench (K).

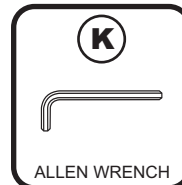
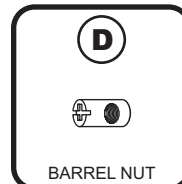
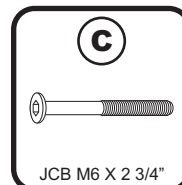
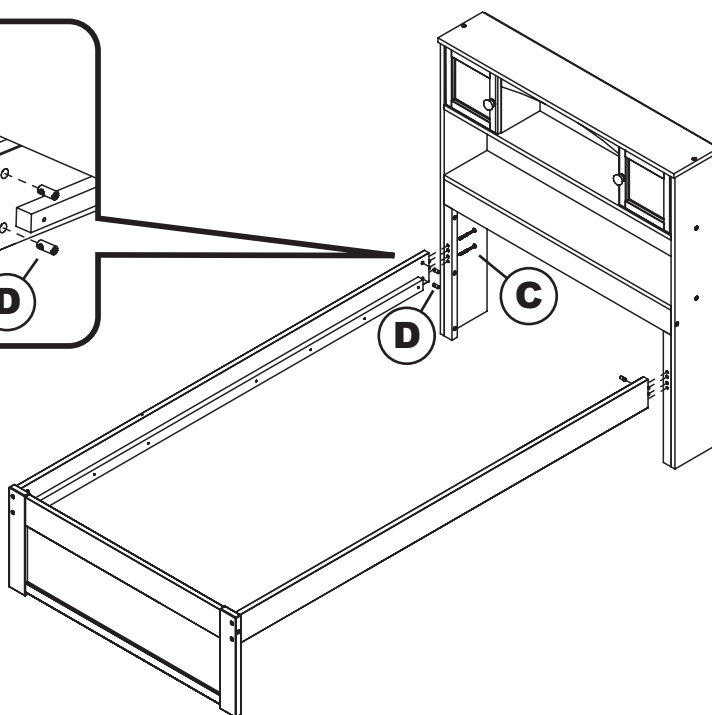
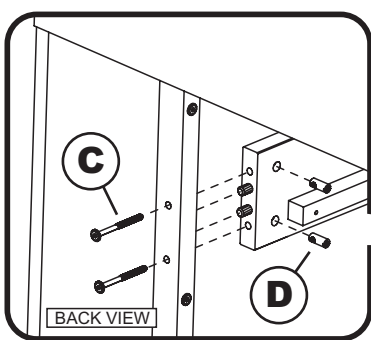

For Slat kit assembly, follow assembly instructions included with slat kit.

**Congratulations !**

Your Newport bookcase bed is now ready for use.  
We recommend that you recheck that all screws are tight,  
and that all parts are secure before use and periodically to ensure lasting Safety.